



# Megatouch FORCE Monitor Chassis Board Replacement

Visit the Merit Industries, Inc. Web site  
<http://www.meritind.com>



merit industries, inc.

PM0337-01 Rev C

## **Table of Contents**

---

---

### **FORCE Classic**

Monitor Chassis Board Removal ..... **p. 1-2**

Monitor Chassis Board Replacement ..... **p. 2-3**

### **FORCE Elite**

Analog to Digital Board Removal..... **p. 3**

Analog to Digital Board Replacement..... **p. 3-4**

### **FORCE Radion**

Monitor Chassis Board Removal ..... **p. 4-5**

Monitor Chassis Board Replacement ..... **p. 5-6**

### **FORCE Upright**

Monitor Chassis Board Removal ..... **p. 6-7**

Monitor Chassis Board Replacement ..... **p. 7**

## Megatouch™ FORCE Monitor Chassis Board Replacement

### **FORCE CLASSIC**

To replace the monitor chassis board in your Megatouch FORCE Classic game:

#### **Monitor Chassis Board Removal**

1. **Turn off the game and unplug it from its power source.**
2. Unlock and remove the coin box or coin box/bill acceptor assembly.
3. Unlock and open the rear door. To remove the lid, first disconnect the fan power connector, then the plastic tubing (from lid end) and ground strap. Also remove the monitor control board attached with velcro to the inside of the game. Then press up on the spring-loaded levers (located on each side of the lid), push the levers forward, and lift and remove the lid. Also remove the front bezel. See Figures 1 and 2.
4. Remove the two thumbnuts securing the touchscreen controller and disconnect the green ground wire with the ring lug that is attached to the metal-work next to the controller.
5. Disconnect the touchscreen controller cable from the back of the controller and disconnect the Molex connector connecting the orange and gray wires (from the touchscreen controller cable) to the harness. Then replace the touchscreen controller on the mounting screws so it does not interfere with the rest of the monitor chassis board replacement process, but do not secure it.
6. Disconnect the monitor signal cable on the motherboard. See Figure 3 for connector location.

7. Disconnect the (2)-pin monitor power connection (black and white wires) from the power supply and the monitor ground wire from the game.
8. Remove the four 11/32" kepnuts securing the monitor chassis to the main chassis; two nuts are located on each side of the monitor board. See Figure 4.

**NOTE: BE CAREFUL TO AVOID THE FLYBACK TRANSFORMER AND HIGH VOLTAGE WIRE RUNNING TO THE MONITOR.**

9. Pick up the monitor assembly and remove it from the cabinet. Be careful of the wires on the neck board.
  10. Remove the (2) screws fastening the chassis board and metal tray to the game (see Figure 5), then carefully position the board assembly so you can make the necessary disconnections.
  11. Remove the ground connector and the monitor signal cable from the neck board. See Figure 6.
  12. Disconnect the 4-pin yoke assembly connector from the monitor chassis board. See Figure 7.
  13. Carefully remove the glue where the neck board connects to the picture tube, then carefully remove the board.
- NOTE: Do not twist the neck board during removal.**
14. Disconnect the A/C power connector from the monitor chassis board. See Figure 7.
  15. Disconnect the degaussing power connector (red wires) from the monitor chassis board. See Figure 7.

16. Carefully remove the high voltage line from the back of the monitor by lifting the rubber seal and pinching the metal prongs until the line can be pulled from the monitor.
17. Carefully remove the monitor chassis board assembly from the game.
26. Loosely reinstall the monitor assembly with the existing hardware, but do not secure it.
27. Reconnect the monitor power connector to the power supply (black and white wires), then reconnect the monitor ground wire.

### ***Monitor Chassis Board Replacement***

18. Carefully place the new chassis board in the game (making sure the flyback transformer (see Figure 7) is at the rear of the game) in a position that allows you to make the necessary reconnections to the board.
19. Carefully replace the high voltage line on the back of the monitor.
20. Reconnect the degaussing power connector (red wires) to the monitor chassis board. See Figure 7.
21. Reconnect the A/C power connector on the monitor chassis board. See Figure 7.
22. Carefully reconnect the yoke assembly on the picture tube.
23. Reconnect the 4-pin neck board connector to the connector labeled "YOKE" on the monitor chassis board. See Figure 7.
24. Reconnect the ground connector and monitor signal cable on the neck board. See Figure 6.
25. Line up the screw holes on the edge of the monitor chassis board with the screw holes inside the game and secure the board to the game with the (2) screws.
28. Reconnect the monitor signal cable to the motherboard. See Figure 3.
29. Route the touchscreen controller connector under the picture tube and away from the flyback transformer. Then reconnect the touchscreen controller cable in the back of the controller and secure the controller with the existing hardware.
30. Reconnect the molex connector connecting the orange and gray wires to the main harness, then place the ring lug on the touchscreen controller ground to the metalwork and secure it with the existing hardware.
31. After replacing the front bezel, make sure all wires are clear of the area. Then install the hood on the chassis, connecting the fan power connector, monitor control board, ground strap, and plastic drain tube. Pull the hood towards you until the spring-loaded levers lock into place.
32. Slide the monitor assembly forward as far as possible until there are no gaps between the bezel and the monitor. Then secure the assembly with the existing hardware.
33. Plug in and turn on the game.
34. Use the SETUP and CALIBRATE buttons and the monitor control board to adjust the monitor settings, if necessary.

35. Close and lock the hood.
36. Replace and lock the coin box or coin box/bill acceptor assembly.

### **FORCE ELITE**

**NOTE: Megatouch FORCE Elite games will not have a monitor chassis board and will instead have an analog to digital board on the reverse side of the display screen.**

To replace the analog to digital board in your Megatouch FORCE Elite game:

#### **Analog to Digital Board Removal**

1. **Turn off the game and unplug it from its power source.**
2. Unlock and open the rear door.
3. Disconnect the monitor power connection running to the power supply.
4. Disconnect the monitor signal cable from the motherboard and remove it from the cable clamps. See Figure 3.
5. Inside the game, access the latches for each side panel and remove both panels (see Figure 8).
6. Remove the two nuts and washers securing the touchscreen controller to the game and remove the controller from the mounting screws. Then disconnect the cable from the back of the controller and disconnect the Molex connector connecting the orange and gray wires (from the touchscreen controller cable) to the main power harness.
7. Remove the (3) screws at the top of each side piece fastening the top cover to the game (see Figure 9) and remove the top cover.

8. Loosen the 5/16" nuts securing the (2) LCD clips (one on each side piece). See Figure 9.
9. Lift the bezel and monitor assembly from the game.
10. Locate the analog to digital board on the reverse side of the LCD display screen. Using Figure 10, disconnect the following connections on the board:
  - monitor signal cable (from J9).

**NOTE: Leave the ground wire attached.**

- LCD connector (from J7)
  - signal and power connector (from J3)
  - on-screen display connector (from J4)
  - DC power connector (from J1)
11. Remove the (4) screws fastening the analog to digital board to the bezel (see Figure 10) and remove the board.

#### **Analog to Digital Board Replacement**

12. Align the new analog to digital board on the bezel with the monitor connector furthest from the top edge of the bezel. Then replace the (4) screws removed in the last step. Be sure to reattach the ground wire from the monitor signal cable (see Figure 10).
13. Using Figure 10, reconnect the following connections on the board:
  - DC power connector (to J1)
  - signal and power connector (to J3)
  - on-screen display connector (to J4)
  - LCD connector (to J7)
  - monitor signal cable (to J9)

14. Replace the monitor assembly, aligning it with the support brackets inside the game and making sure the LCD clips fit properly into the slots at the top of each side. See Figure 9.
15. Tighten the nuts securing the (2) LCD clips. See Figure 9.
16. Replace the top cover and secure it with the (3) screws at the top of each side piece. The shorter screw will go in the screw hole closest to the rear of the game. See Figure 9.
17. Connect the touchscreen controller cable in the back of the touchscreen controller and secure the controller on the mounting screws in the game with the existing hardware. Also reconnect the molex connector connecting the orange and gray wires to the main power harness.
18. Replace both side panels.
19. Reconnect the monitor power connector to the power supply.
20. Route the monitor signal cable through the cable clamps and reconnect it to the motherboard. See Figure 3 for location.
21. Plug in and turn on the game.
22. Use the SETUP and CALIBRATE buttons and the monitor control board to adjust the monitor settings, if necessary.
23. Close and lock the rear door.

### **FORCE RADION**

**NOTE: When replacing the monitor chassis board in Megatouch FORCE Radion games, you will need to remove the chassis board from the metal mounting tray before returning the**

**chassis board, as the replacement chassis board will not include a mounting tray.**

To replace the monitor chassis board in your Megatouch FORCE Radion game:

### **Monitor Chassis Board Removal**

**NOTE: Be extremely careful of the picture tube and monitor adjustment controls.**

1. **Turn off the game and unplug it from its power source.**
2. Unlock and open both side doors and the rear door.
3. Remove the screw securing the strain relief cord to the rear door, then remove the monitor control board from the velcro on the rear door.
4. Remove the screws holding the rear bezel to the game. Five (5) screws are located along the top edge of the game and (2) are at the bottom rear of each side of the game. See Figure 11.
5. Lift the rear bezel from the game.
6. Disconnect the hard drive ribbon cable from the motherboard (See Figure 3). Then remove the (3) screws securing the hard drive mounting bracket to the game (See Figure 12) and remove the hard drive assembly.
7. Using Figure 3, disconnect the following connections on the motherboard:
  - monitor signal cable
  - touchscreen controller connector
  - Ethernet cable
  - I/O board connector
  - motherboard power connector
  - audio board connector
  - centronics connector

8. Disconnect the touchscreen power connector (orange and gray wires) and the 4-pin centronics power connector from the power supply harness.  
  
Disconnect the centronics power connector and touchscreen power connector.
9. Unscrew the (2) thumbscrews securing the motherboard assembly, then remove the motherboard from the game.
10. Unscrew the thumbscrew securing the fan assembly (see Figure 12), disconnect the 2-pin fan power connector, and remove the fan assembly from the game.
11. If your game has an angled bracket on the edge of the monitor chassis board, unscrew and remove it. This bracket is only used for shipping and can be discarded. See Figure 12.
12. Remove the ground connector from P901 and the monitor signal cable from P501 on the neck board. Cut the tie wraps if necessary. See Figure 13.
13. Disconnect the 4-pin neck board connector from the monitor chassis board (P401). See Figure 14.
14. Carefully remove the glue where the neck board connects to the picture tube, then carefully remove the board.  
  
**NOTE: Do not twist the neck board during removal.**
15. Reaching in from the top of the game, disconnect the A/C power connector from the monitor chassis board. See Figure 14.
16. Disconnect the degaussing power connector (blue and brown wires) from P802 on the monitor chassis board. See Figure 14.
17. Disconnect the rotation switch connector (black and red wires) from P202 on the monitor control board.
18. Carefully remove the high voltage line from the back of the monitor by lifting the rubber seal and pinching the metal prongs until the line can be pulled from the monitor.
19. Unscrew the (2) thumbscrews securing the monitor chassis board and metal tray to the game and carefully remove the monitor chassis board, neck board, and monitor control board. Then remove the (4) screws securing the monitor chassis board to the metal tray (see Figure 14). The tray will be used to mount the replacement chassis board.

### **Monitor Chassis Board Replacement**

20. Mount the new monitor chassis board to the metal tray using the (4) screws that were removed in the last step.
21. Carefully replace the chassis board assembly, making sure the A/C power connector is at the rear of the game. The thumbscrews used to secure the board assembly must line up with the screw holes on the bottom of the game. Once the board is correctly aligned, tighten the (2) thumbscrews.
22. Carefully replace the high voltage line on the back of the monitor.
23. Reconnect the rotation switch connector (black and red wires) at P202 on the monitor control board.
24. Reconnect the degaussing power connector (blue and brown wires) at P802 on the monitor chassis board. See Figure 14.

25. Reconnect the A/C power connector on the monitor chassis board. See Figure 14.
26. Carefully reconnect the neck board on the picture tube.
27. Reconnect the 4-pin yoke assembly connector at P401 on the monitor chassis board. See Figure 14.
28. Reconnect the ground connector at P901 and the monitor signal cable at P501 on the neck board. See Figure 13.
29. Replace the fan assembly, reconnect the 2-pin fan power connector, and tighten the thumbscrew to secure the fan assembly to the game. See Figure 12.
30. Replace the motherboard and tighten the (2) thumbscrews to secure the motherboard assembly to the game.
31. Reconnect the centronics power connector and touchscreen power connector to the power supply harness.
32. Using Figure 3, reconnect the following connections on the motherboard:
  - monitor signal cable
  - touchscreen controller connector
  - Ethernet cable
  - I/O board connector
  - motherboard power connector
  - audio board connector
  - centronics connector
33. Replace the hard drive assembly and the (3) screws to secure the hard drive mounting bracket to the game. Then reconnect the hard drive ribbon cable to the motherboard. See Figure 3.
34. Replace the rear bezel and the (7) screws ((5) along the top edge, (2) at the bottom rear) holding the bezel to the game.
35. Replace the screw securing the strain relief cord to the rear door, then replace the monitor control board on the velcro attached to the rear door.
36. Plug in and turn on the game.
37. Use the SETUP and CALIBRATE buttons and the monitor control board to adjust the monitor settings, if necessary.
38. Close and lock the rear door, then replace and lock both side doors.

#### **FORCE UPRIGHT**

To replace the monitor chassis board in your Megatouch FORCE Upright game:

#### **Monitor Chassis Board Removal**

**NOTE:** *Be extremely careful of the picture tube and monitor adjustment controls.*

1. **Turn off the game and unplug it from its power source.**
2. Unlock and open the rear door.
3. Remove the (4) screws and spacers fastening the upper part of the neck board bracket to the game, then remove the (3) remaining screws and remove the bracket. See Figure 15.
4. Remove the monitor signal cable from P901 and the ground connector from GND-4 on the neck board. Then remove the second ground connector from GND-3. See Figure 16.
5. Carefully remove the glue where the neck board connects to the picture tube, then carefully remove the board.



**NOTE: Do not twist the neck board during removal.**

6. Disconnect the degaussing power connector (black wires) from SW101 on the monitor chassis board. See Figure 17.
  7. Disconnect the rotation switch connector (black and red wires) on the monitor chassis board. See Figure 17.
  8. Disconnect the 4-pin yoke assembly connector (blue, brown, yellow, and red wires) from J127 on the monitor chassis board. See Figure 17.
  9. Carefully remove the high voltage line from the back of the monitor by lifting the rubber seal and pinching the metal prongs until the line can be pulled from the monitor.
  10. Remove the screw securing the A/C power cable clamp to the metal mounting frame (see Figure 18), then disconnect the A/C power connector from the monitor chassis board (See Figure 17).
  11. Remove the monitor control board from the velcro on the inside of the game.
  12. Remove the remaining (3) screws securing the monitor chassis board assembly to the game (see Figure 18) and carefully remove the monitor chassis board, neck board, and monitor control board.
- cable clamp to the metal frame. Then replace the remaining (3) screws to secure the monitor chassis board assembly to the game.
14. Replace the monitor control board on the velcro on the inside of the game.
  15. Carefully replace the high voltage line on the back of the monitor.
  16. Carefully reconnect the neck board on the picture tube.
  17. Reconnect the 4-pin yoke assembly connector (blue, brown, yellow, and red wires) to J127 on the monitor chassis board. See Figure 17.
  18. Reconnect the rotation switch connector (black and red wires) on the monitor chassis board. See Figure 17.
  19. Reconnect the degaussing power connector (black wires) to SW101 on the monitor chassis board. See Figure 17.
  20. Reconnect the monitor signal cable to P901 and the ground connector to GND-4 on the neck board. Then reconnect the second ground connector from GND-3. See Figure 16.
  21. Replace the neck board bracket and fasten the bottom of the bracket with the (3) screws removed in step 3, then the upper part of the bracket with the (4) screws and spacers.
  22. Plug in and turn on the game.
  23. Use the SETUP and CALIBRATE buttons and the monitor control board to adjust the monitor settings, if necessary.
  24. Close and lock the rear door.

**Monitor Chassis Board Replacement**

13. Carefully replace the new chassis board assembly with the A/C power connector towards the bottom of the game. Once the board is correctly aligned, reconnect the A/C power connector on the monitor chassis board and replace the screw securing the

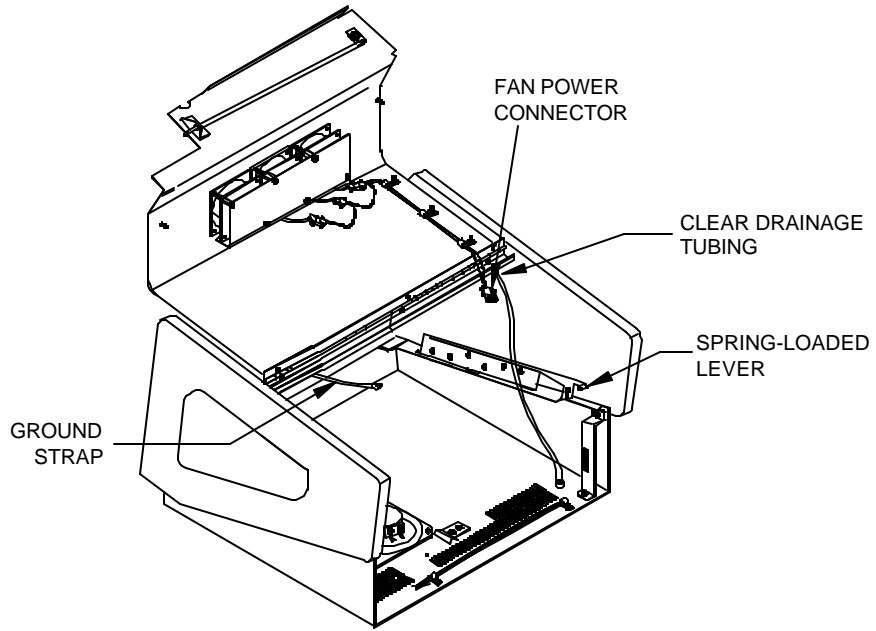

FIGURE 1 - FORCE CLASSIC HOOD ASSEMBLY

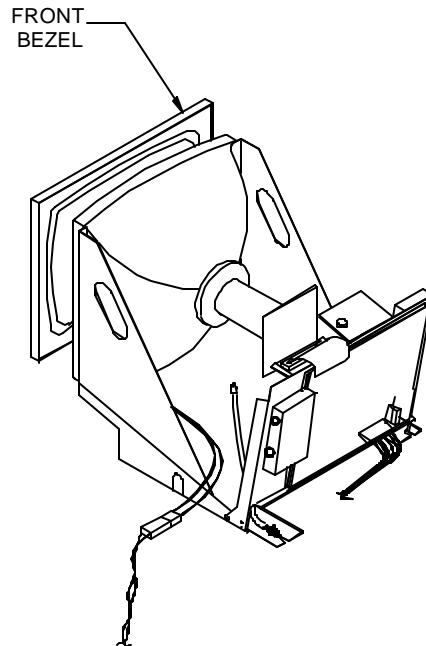

FIGURE 2 - FORCE CLASSIC MONITOR ASSEMBLY

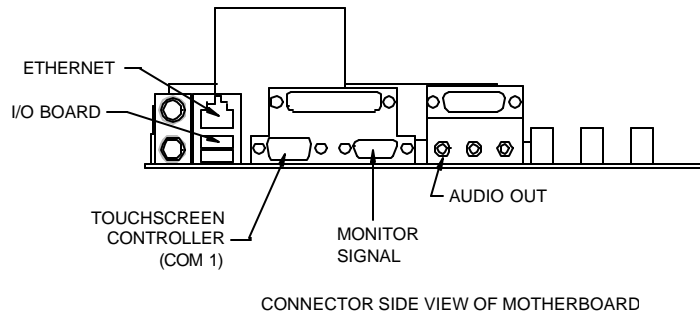
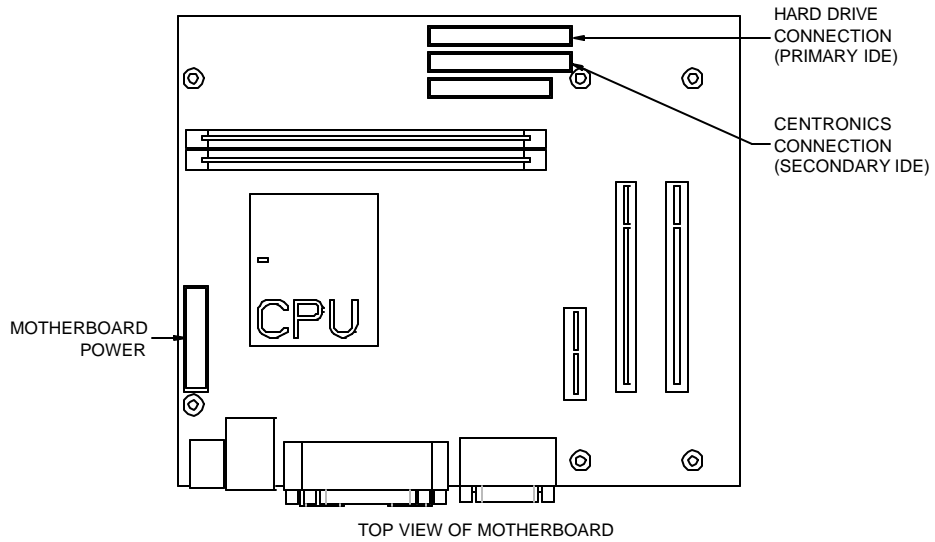

FIGURE 3 - ECS MOTHERBOARD CONNECTIONS

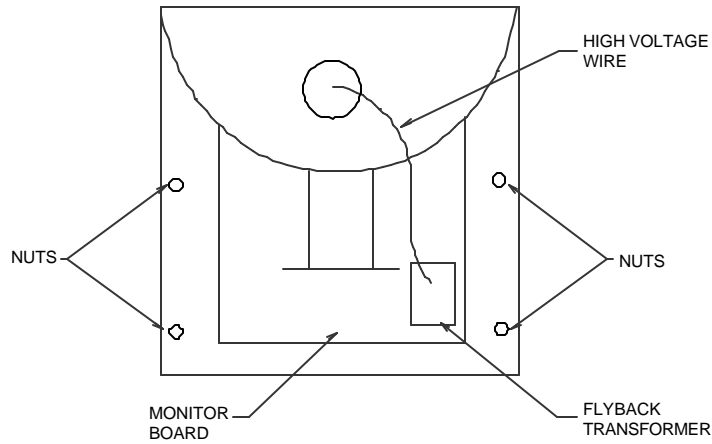

FIGURE 4 - FORCE CLASSIC - LOCATION OF NUTS FOR REMOVING MONITOR ASSEMBLY



FIGURE 5 - FORCE CLASSIC - CHASSIS BOARD MOUNTING TRAY

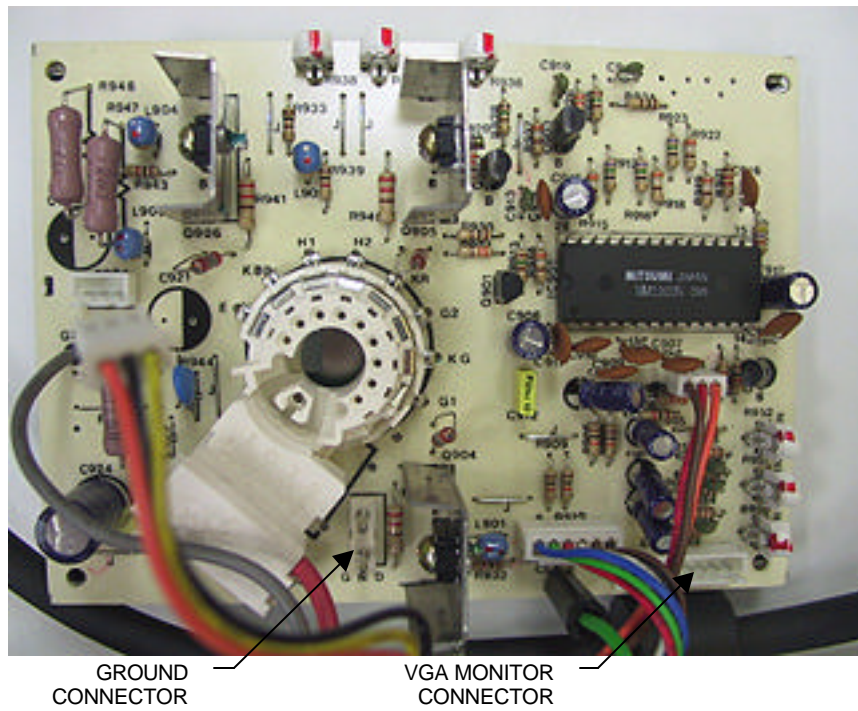

FIGURE 6 - FORCE CLASSIC NECK BOARD

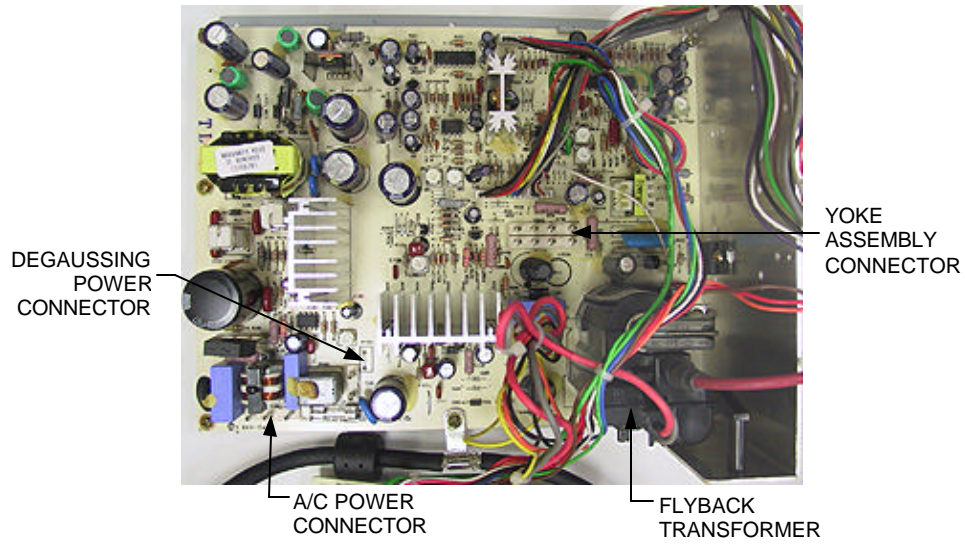

FIGURE 7 - FORCE CLASSIC CHASSIS BOARD

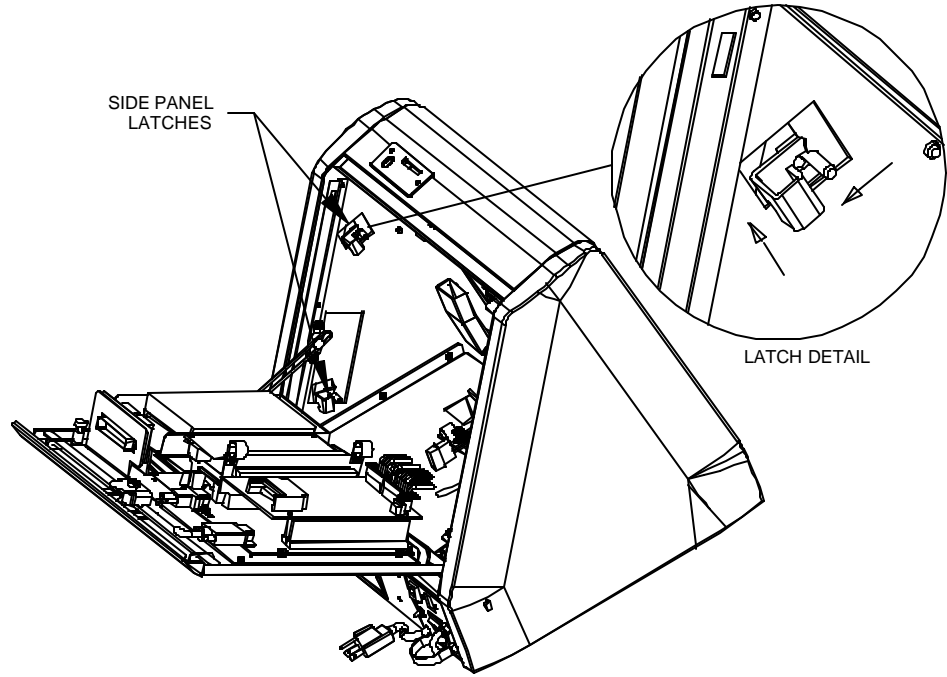

FIGURE 8 - FORCE ELITE SIDE PANEL LATCH ACCESS

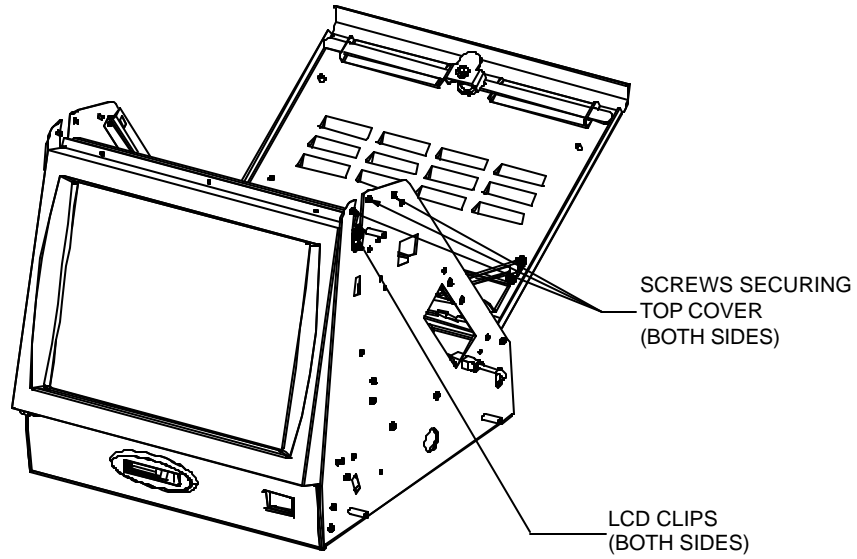

FIGURE 9 - FORCE ELITE FRONT BEZEL

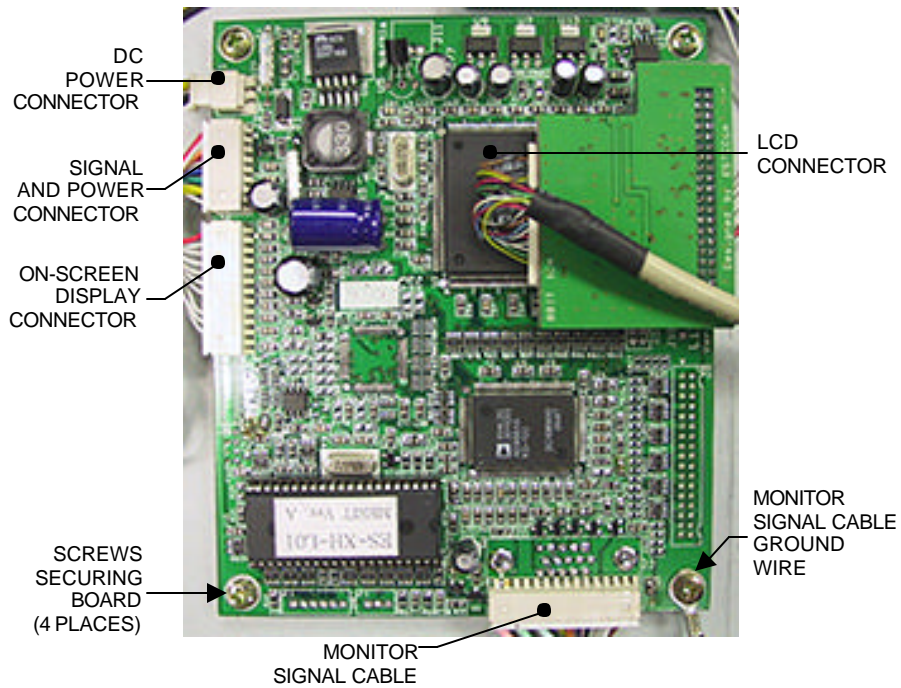

FIGURE 10 - FORCE ELITE ANALOG TO DIGITAL BOARD

COPYRIGHT © 2002 MERIT INDUSTRIES, INC.

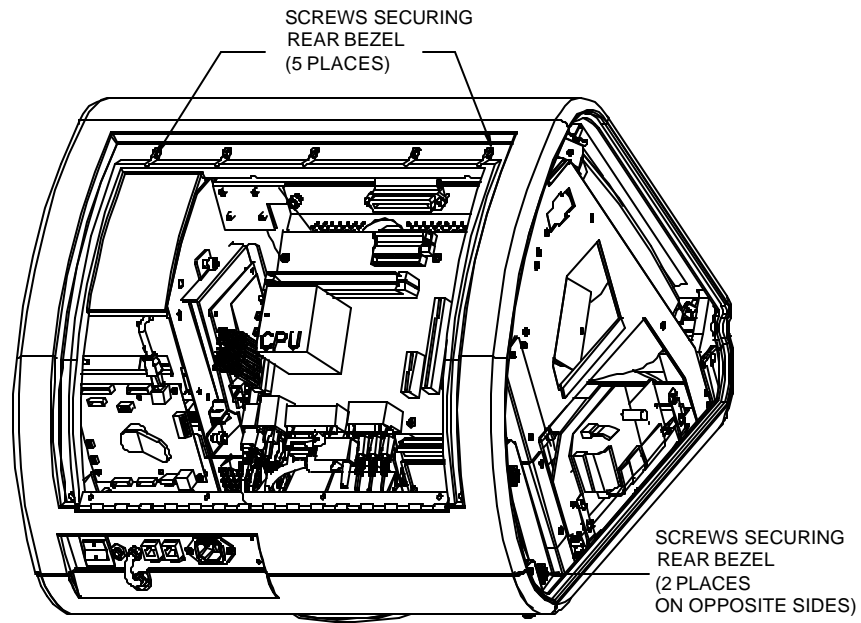
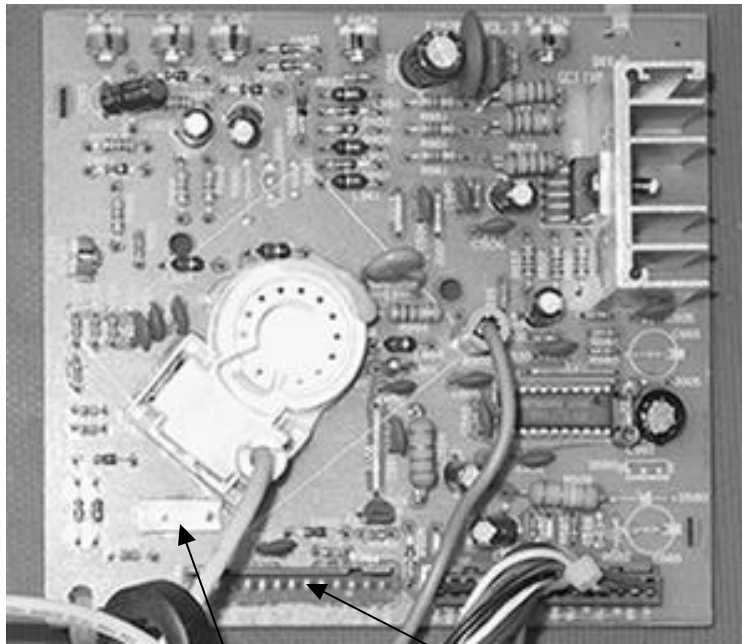

FIGURE 11 - FORCE RADION - SCREWS SECURING REAR BEZEL

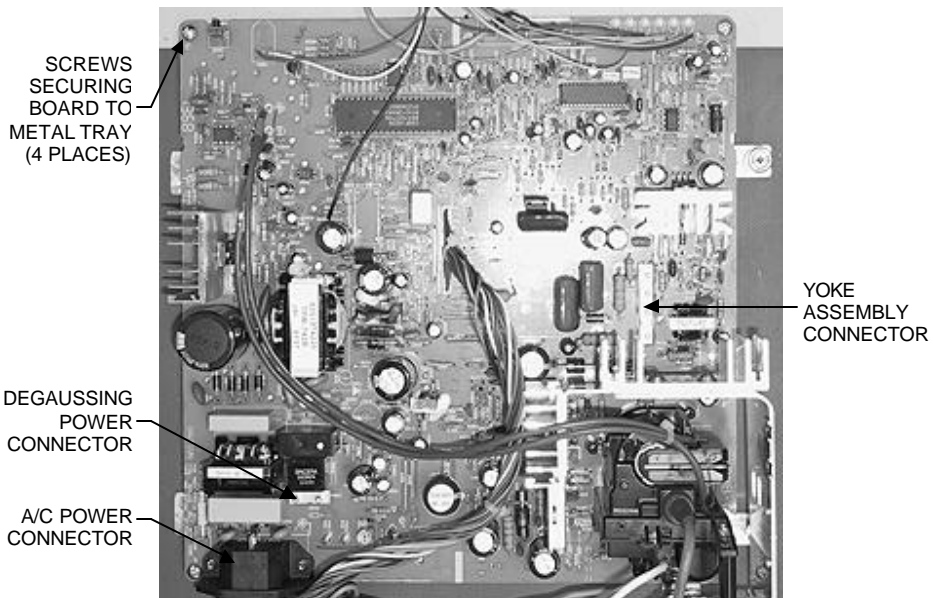

FIGURE 12 - FORCE RADION - SIDE VIEW



GROUND CONNECTOR      MONITOR SIGNAL CONNECTOR

FIGURE 13 - FORCE RADION NECK BOARD



SCREWS  
SECURING  
BOARD TO  
METAL TRAY  
(4 PLACES)

DEGAUSSING  
POWER  
CONNECTOR

A/C POWER  
CONNECTOR

YOKE  
ASSEMBLY  
CONNECTOR

FIGURE 14 - FORCE RADION MONITOR CHASSIS BOARD



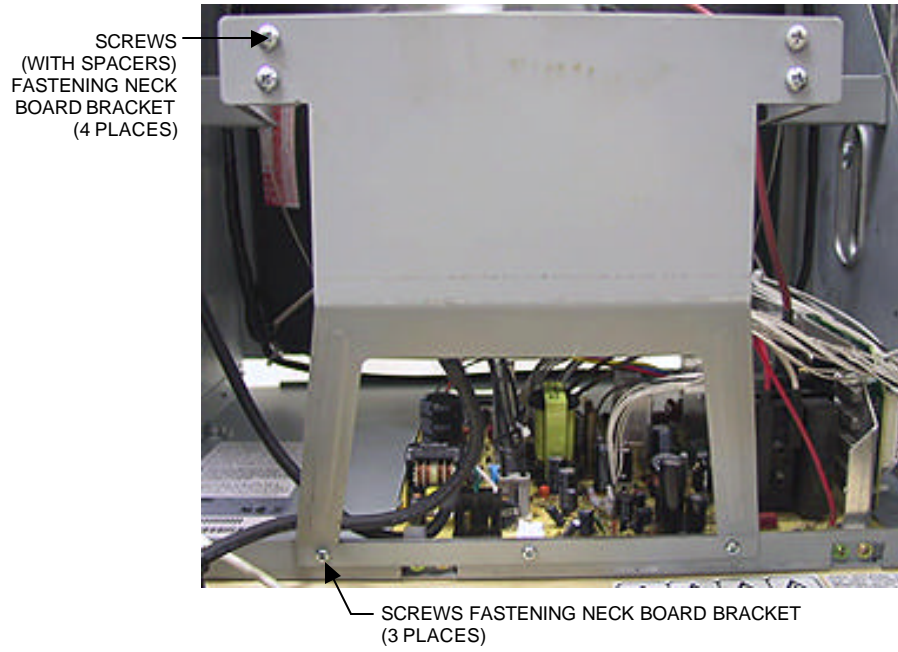

FIGURE 15 - FORCE UPRIGHT NECK BOARD BRACKET

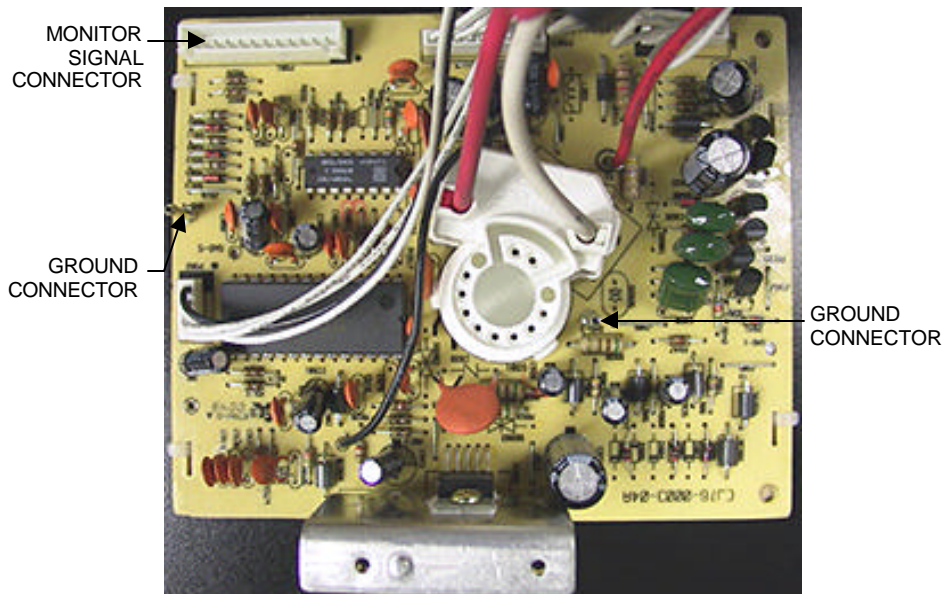

FIGURE 16 - FORCE UPRIGHT NECK BOARD

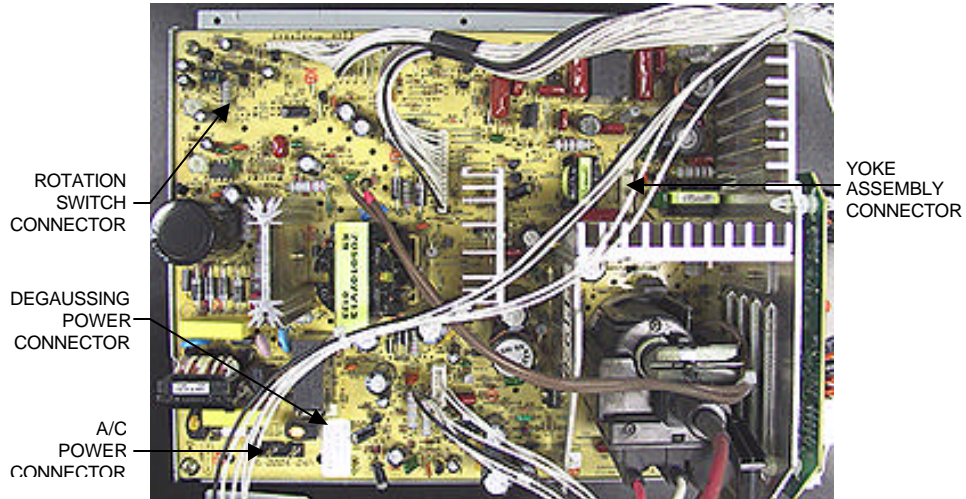

FIGURE 17 - FORCE UPRIGHT MONITOR CHASSIS BOARD

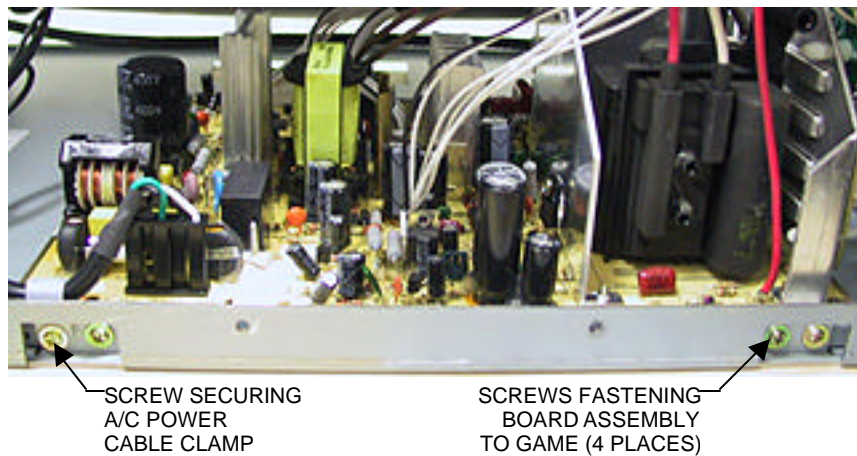

FIGURE 18 - FORCE UPRIGHT - SCREWS FASTENING MONITOR CHASSIS BOARD TO GAME







MEGATOUCH FORCE MONITOR CHASSIS BOARD REPLACEMENT  
PM0337-01 Rev C